

ADJUSTABLE LOUVERS

UPO-250



UMBELCO

PROTECCIÓN SOLAR DE EDIFICIOS

PROTEGE
FUNCIONA
EMBELLECE
RESISTE

www.umbelco.com



UPO-250

THE PRODUCT

The UPO-250 is the first of our big sized louvers. It shares most of the technical advantages of the UPO-150, and takes them to its limit, becoming a perfect option for big size hollows. It adds a modern looking to the sun-shading efficiency, in which it can achieve great numbers like the maximum length of its slats (up to 360cms) or the manual handling for hollows of up to 20 m².

The UPO-250 combines a user-friendly design with great performance and low cost maintenance.

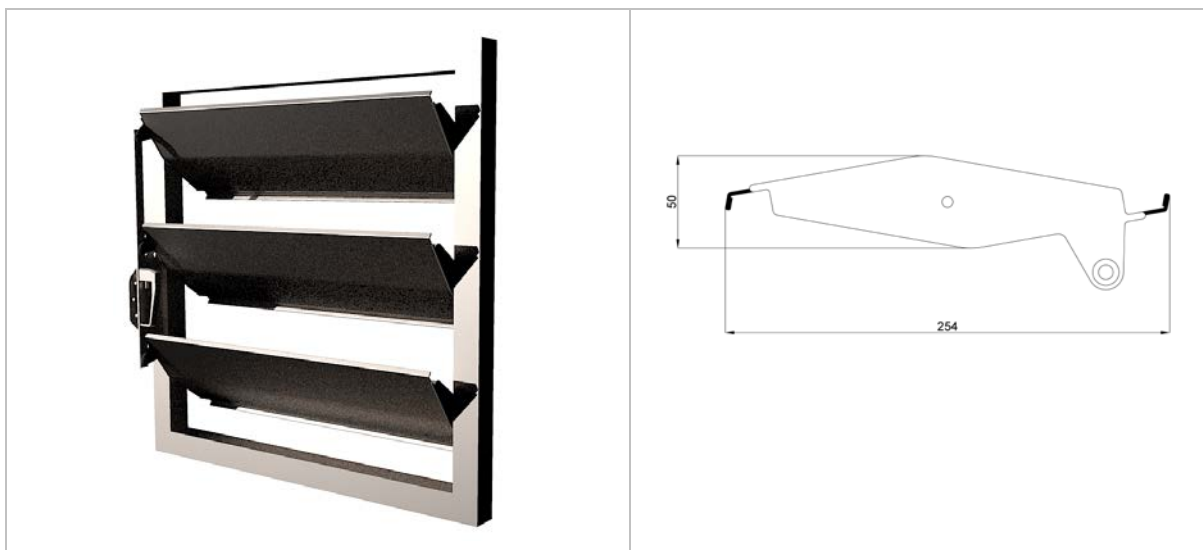

PROJECT DESCRIPTION

UMBELCO patented aluminium louvers model UPO-250, composed of horizontal / vertical adjustable slats fitting together, with a diamond shape of 250 mm wide, 40 mm thickness. PV4-high-strength classification according to UNE 85-226-87 and UNE 85-227-87. Continuous painted aluminium band (by COIL COATING process), high weather resistance by salted fog test (more than 400 hours in WEISS SSC 450 chamber). Polyamide end caps (nylon) with high resistance aluminium pivot axis (8 mm) and housed in extruded aluminium frame, anodised or painted. Manual drive/electric, even pp of fasteners, assembly and cleaning..



UMBELCO

Pol. Las Norias, Avda. Valencia, parcela nº 6
50.450 MUEL (ZARAGOZA)
Tel: +34 976 14 52 56 Fax: +34 976 14 52 57
umbelco@umbelco.com
<http://www.umbelco.com>



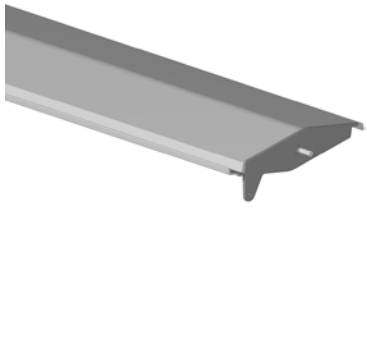

UPO-250

COMPONENTS

		
UPO-250 Slats with its nylon end caps and aluminium pivot	Aluminium frame with built-in proportional part of handling system.	Handling and synchronization system

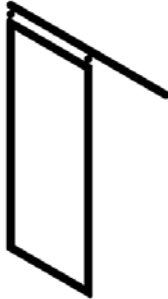
SPECIAL FRAMES AVAILIABLE

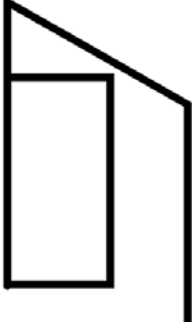
			
Sliding frame	Hinged frame	Vertical folding frame	Horizontal Folding frame

ADDITIONAL OPTIONS

		
Different colours slats (inside-outside)	Zinc, steel, copper, etc slats (under request)	Perforated slats available

UMBELCO

Pol. Las Norias, Avda. Valencia, parcela nº 6
50.450 MUEL (ZARAGOZA)

Tel: +34 976 14 52 56

Fax: +34 976 14 52 57

umbelco@umbelco.com







<http://www.umbelco.com>



UPO-250

SOLUTIONS

Wide range of special solutions

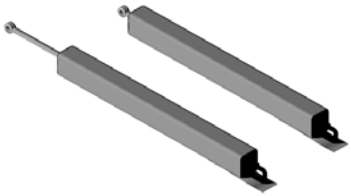
		
Horizontal system	Vertical system	Cross-less frames
		
Trapezoid frames	Crank handling	On-slats handling
		
Electric handling		

STANDARD COLOURS

White and silver, others confirm..

UMBELCO

Pol. Las Norias.Avda. Valencia, parcela nº 6
50.450 MUEL (ZARAGOZA)

Tel: +34 976 14 52 56

Fax: +34 976 14 52 57

umbelco@umbelco.com

<http://www.umbelco.com>



QUALITY SEALS

ISO 9001, ISO 14001

Certificado

Norma de aplicación **ISO 9001:2008**

Nº registro certificado 0.04.14363

TÜV Rheinland Ibérica Inspection, Certification & Testing S.A.
certifica:

Titular del certificado: **UMBELCO, S.L.**
Pol. Las Norias - Avda. Valencia, Parcela 6
E - 50450 Muel (Zaragoza)

Ámbito de aplicación: Diseño, producción e instalación de protecciones solares para la construcción.

Mediante auditoría realizada, según consta en el informe nº 14363 se verificó el cumplimiento de los requisitos recogidos en la norma ISO 9001:2008.

La fecha límite para la auditoría de seguimiento es 09-01 (dd.mm).

Validez: Este certificado es válido desde 2015-02-14 hasta 2018-02-13.
Fecha de primera certificación 2009-02-13.

2015-02-24 TÜV Rheinland Ibérica Inspection, Certification & Testing S.A.
Garroba, 10-12 - E-08820 El Prat de Llobregat

www.tuv.com



 **TÜVRheinland®**
Precisely Right.

UMBELCO

Pol. Las Norias, Avda. Valencia, parcela nº 6
50.450 MUEL (ZARAGOZA)

Tel: +34 976 14 52 56

Fax: +34 976 14 52 57

umbelco@umbelco.com

<http://www.umbelco.com>



Certificado

Norma de aplicación **ISO 14001:2004**

Nº registro certificado 3.00.14122

TÜV Rheinland Ibérica Inspection, Certification & Testing S.A.
certifica:

Titular del certificado: **UMBELCO, S.L.**
Pol. Las Norias - Avda. Valencia, Parcela 6
E - 50450 Muel (Zaragoza)

Ámbito de aplicación: Diseño, producción e instalación de protecciones solares para la construcción.

Mediante auditoría realizada, según consta en el informe nº 14122 se verificó el cumplimiento de los requisitos recogidos en la norma ISO 14001:2004.

La fecha límite para la auditoría de seguimiento es 09-01 (dd.mm).

Validez: Este certificado es válido desde 2015-02-14 hasta 2018-02-13.
Fecha de primera certificación 2009-02-13.

2015-02-24 TÜV Rheinland Ibérica Inspection, Certification & Testing S.A.
Garrotxa, 10-12 - E-08820 El Prat de Llobregat

www.tuv.com



CE MARKINGS



DECLARACIÓN DE CONFORMIDAD

UMBELCO, S.L.
Pol. Las Norias. Avda. Valencia, parcela nº 6
50.450 MUEL (Zaragoza)

Declara bajo su exclusiva responsabilidad la conformidad del producto:

UPO-250

al que se refiere esta declaración, con las disposiciones del Reglamento de Productos de Construcción (UE) N° 305/2011 que sustituye a la la Directiva 89/106/CEE (derogada el 1 de julio de 2013), para lo cual se han seguido las normas siguientes:

UNE-EN 13527:2000

UNE-EN 12045:2000

UNE-EN 14201:2004

UNE-EN 12194:2000

UNE-EN 12216:2002

UNE-EN 14203:2004

UNE-EN 13125:2001

UNE-EN 14501:2006

UNE-EN 1932:2014

En Zaragoza a 11 de julio de 2008

Fdo. Daniel Morillo
D. Gerente

UMBELCO

Pol. Las Norias. Avda. Valencia, parcela nº 6
50.450 MUEL (ZARAGOZA)

Tel: +34 976 14 52 56

Fax: +34 976 14 52 57

umbelco@umbelco.com

<http://www.umbelco.com>



Management
System
ISO 9001:2008
ISO 14001:2004
www.tuv.com
ID 9105081907



Pol. Las Norias.Avda. Valencia, parcela nº 6
50.450 MUEL (ZARAGOZA)

Tel: +34 976 14 52 56

Fax: +34 976 14 52 57

umbelco@umbelco.com

<http://www.umbelco.com>